

# FAIRBANKS®

## FB 2250 SERIES DIGITAL INSTRUMENT



Fairbanks' FB 2250 Series Digital Instrument is available in a rugged black ABS plastic or 304 series stainless steel enclosure. The FB 2250 raises the bar for digital weight instruments by offering numerous features for a variety of applications.

### PERFORMANCE APPLICATIONS

The FB 2250 Series is designed for optimal operation in a wide variety of applications including:

- System Integration
- Food Processing
- Batching
- Stress Testing
- Process Control
- Filling

### SPECIFICATIONS

Display	1.0" high, 6-digit, green backlit LCD
Enclosure	Black ABS plastic, NEMA 1 rated; Stainless steel, NEMA 4X rated
Pushbutton Keys	Zero, Print, Units, Tare, On/Off, B/G Net
Units	lb, kg, oz, g, lb-oz or custom
Capacity	Selectable 0 to 999,999
Graduation Size	0.0001 to 50
Load Cells	Up to eight 350Ω cells or 16 1000Ω cells
Power Requirements	Choice of AC or AC/DC (requires 5 "D" cell batteries)
Mounting	Desk / Wall mount stand (all models)
Output	COM 1 (standard): RS232, RS422, RS485; COM 2 (standard): RS232, RS422, RS485, 20 mA
Accessories	Bluetooth® wireless technology; 4-20 mA module; Profibus; DeviceNet
Approvals	NTEP CC# 09-023, MC (pending), ETL

### SPECIAL FEATURES

- Combine FB 2250 options and accessories to create the perfect indicator for any application.
- Capture peak weight for ISO required stress test analysis.
- Accumulation feature eliminates manual tracking.
- Tailor your FB 2250 using customer units, custom ticket formats and programmable RS232 output.
- Convert any scale into a counting scale by activating the FB 2250's piece counting feature.

### ABS PLASTIC ENCLOSURE

(Stainless steel bracket included — Battery power optional)

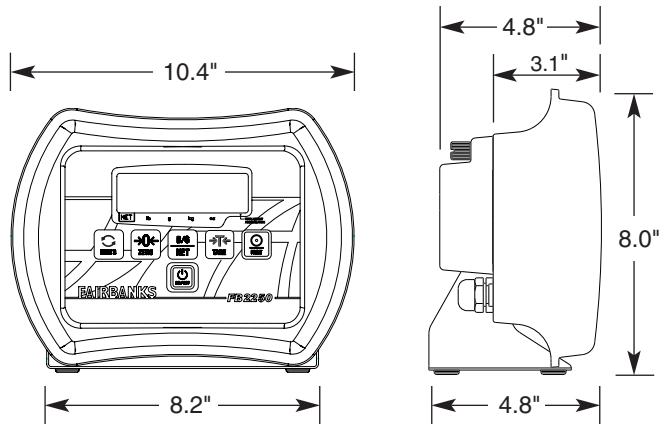

### STAINLESS STEEL ENCLOSURE

(Stainless steel bracket included — Battery power optional)

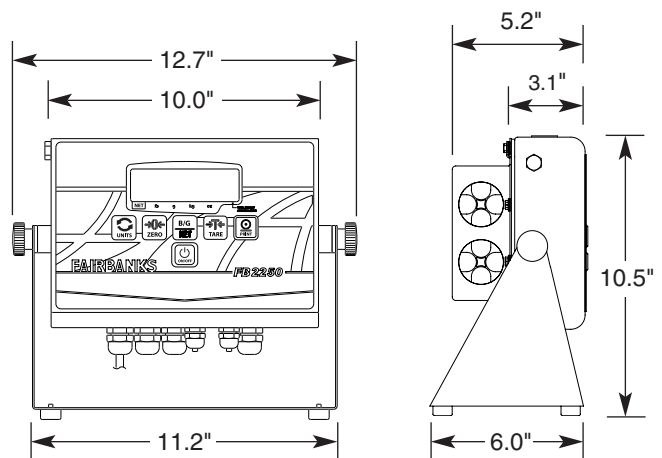

### QuickFacts™

Models and specifications subject to change without notice.  
Printed in the USA. © Fairbanks Scales Inc. www.fairbanks.com

The Bluetooth® word mark and logos are owned by the Bluetooth® SIG, Inc. and any use of such marks by Fairbanks Scales is under license. Other trademarks and trade names are those of their respective owners.



St. Johnsbury manufacturing facility registered in compliance with ISO 9001:2000.

Call toll-free for the Fairbanks representative nearest you:

**(800) 451-4107**

03/09 100444